

**DIGITEK**

**DIGITEK-ILT**

Energy Saving Device  
For  
Fluorescent Light and HID  
**(50Hz)**

DIGITEK TECHNOLOGY CO., Ltd.

### 1. Features:

**Save what should be saved – Energy:** For power supply voltage about or above rated voltage, DIGITEK-ILT can save electricity 15% or more.

**Prolong what should be prolonged – Life Span:** DIGITEK-ILT lowers the voltage, and therefore the temperature of fluorescent light tube or HID bulb and ballast. As a result the life span of tube and ballast is prolonged.

**Maintain what should be maintained – Luminosity:** Maintain the luminosity as required by the design.

### 2. Applications:

Homes, offices, convention centers, factories, street lights and more.

### 3. Models:

#### Fluorescent Light

MODEL	RATED VOLTAGE	RATED CURRENT	FREQUENCY	ALLOWED TOTAL W
SLT10120S50	120V	10A	50Hz	LESS THAN 450W
SLT15120S50	120V	15A		LESS THAN 700W
SLT25120S50	120V	25A		LESS THAN 1200W
SLT40120S50	120V	40A		LESS THAN 1900W

For 110V, 220V, 230V, 240V, 277V units, please contact DIGITEK.

#### Mercury Vapor HID & HID (Sodium)

MODEL	RATED VOLTAGE	RATED CURRENT	FREQUENCY	ALLOWED TOTAL W
SLT3.5120L50	120V	3.5A	50Hz	LESS THAN 300W
SLT07120L50	120V	7A		LESS THAN 600W
SLT12120L50	120V	12A		LESS THAN 1000W

For 110V, 220V, 230V, 240V, 277V units, please contact DIGITEK.

#### 4. Voltage Drop and Energy Saving

4.a. The energy saving is bigger when the voltage drop is larger.

4.b. There are two dipswitches for voltage drop adjustment.

Larger voltage drop

Smaller voltage drop

1. ON 2. ON > 1. OFF 2. ON > 1. ON 2. OFF > 1. OFF 2. OFF

4.c. Default setting: 1.ON 2.OFF

#### 5. Energy Saving Characteristics

5.a. The output starts 2 ~ 3 seconds after power supply is switched on. After 60 seconds for fluorescent light and 15 minutes for HID the voltage gradually drops and starts to save energy.

5.b. Over current protection: When the current is over the rated current, DIGITEK will stop the output. The larger the over current is, the sooner DIGITEK stops the output.

5.c. For fluorescent energy saver, depending on current the energy saving is different:

Larger energy saving

Smaller energy saving

No energy saving

i. SLT010AS50:

Larger energy saving: The current is 1.3A ~ 9.5A, but from smaller energy saving or no energy saving returning to larger energy saving the current has to be larger than 2.6 A.

Smaller energy saving: The current is 0.75A ~ 1.3A, but from no energy saving returning to smaller energy saving the current has to be larger than 1.3A and from no energy saving to larger energy saving the current has to be larger than 2.6A.

No energy saving: The current is smaller than 0.75A.

ii. SLT015AS50:

Larger energy saving: The current is 2.0A ~ 14A, but from smaller energy saving or no energy saving returning to larger energy saving the current has to be larger than 4.0A.

Smaller energy saving: The current is 1.5A ~ 2.0A, but from no energy saving returning to smaller energy saving the current has to be larger than 2.0A and from no energy saving to larger energy saving the current has to be larger than 4.0A.

No energy saving: The current is smaller than 1.5A.

iii. SLT025AS50:

Larger energy saving: The current is 1.7A ~ 24A, but from smaller energy saving or no energy saving returning to larger energy saving the current has to be larger than 4.8A.

Smaller energy saving: The current is 1.0A ~ 1.7A, but from no energy saving returning to smaller energy saving the current has to be larger than 1.7A and from no energy saving to larger energy saving the current has to be larger than 4.8A.

No energy saving: The current is smaller than 1.0A.

iv. SLT040AS50:

Larger energy saving: The current is 2.5A ~ 39A, but from smaller energy saving or no energy saving returning to larger energy saving the current has to be larger than 7.6A.

Smaller energy saving: The current is 1.0A ~ 2.5A, but from no energy saving returning to smaller energy saving the current has to be larger than 2.5A and from no energy saving to larger energy saving the current has to be larger than 7.6A.

No energy saving: The current is smaller than 1.0A.

## **6. Notes on Installation:**

6.a. Connect DIGITEK-ILT in between power supply and ballast of the light.

6.b. No capacitors are allowed between DIGITEK-ILT and ballasts. Capacitors can be installed before DIGITEK-ILT without effecting the normal operation of DIGITEK-ILT.

6.c. Mount DIGITEK-ILT at a proper location sturdily with good ventilation.

6.d. A DIGITEK-ILT unit can control more than one lighting device, but the total current at rated voltage should not exceed the rated current of that unit. This is to avoid overload due to increase of the supplied voltage. Raise of voltage will raise current accordingly.

6.e. The total current of the lighting system should include that of lamps and ballasts.

6.f. For a lighting system the voltage near the end of the line might have too much voltage drop such that the voltage is only high enough to maintain the lighting device to work properly. Installation of DIGITEK-ILT should take

into consideration of this situation. For example, on a line of street lights the voltage close to the power supply might be higher than the rate voltage, but near the end of the line the voltage might be below the rated voltage but enough for normal operation. If we install an energy device near the power supply, then the voltage near the end of the line might be too low for the lighting device to operate properly. In this case, one should install a DIGITEK-ILT on each lamp, and on those lamps near the end there is no point to install any energy saver.

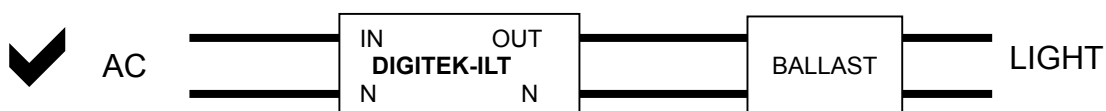

Fig.6.a. Connect DIGITEK in between power supply and ballast of the light.

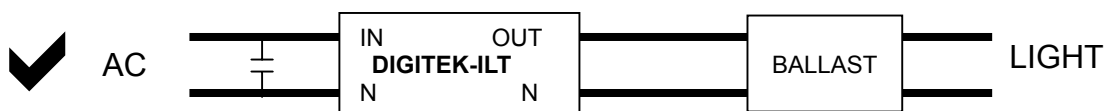

Fig.6.b. Connect capacitor before DIGITEK.

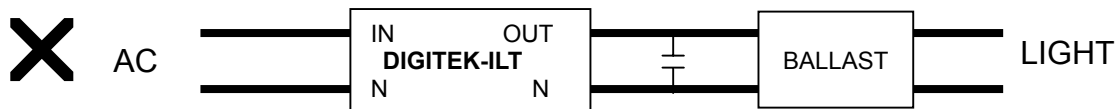

Fig. 6.c. Do not connect capacitor after DIGITEK.

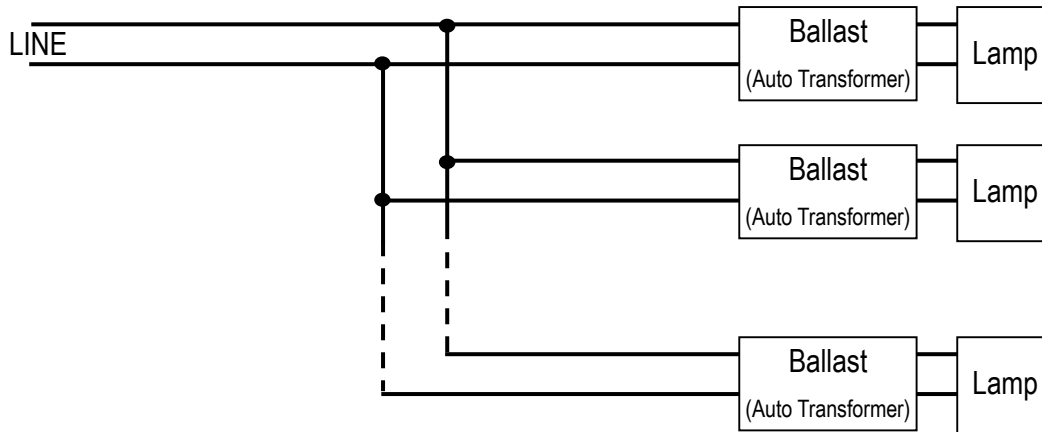

Fig. 6.4 Wire diagram for a lighting system without capacitor.

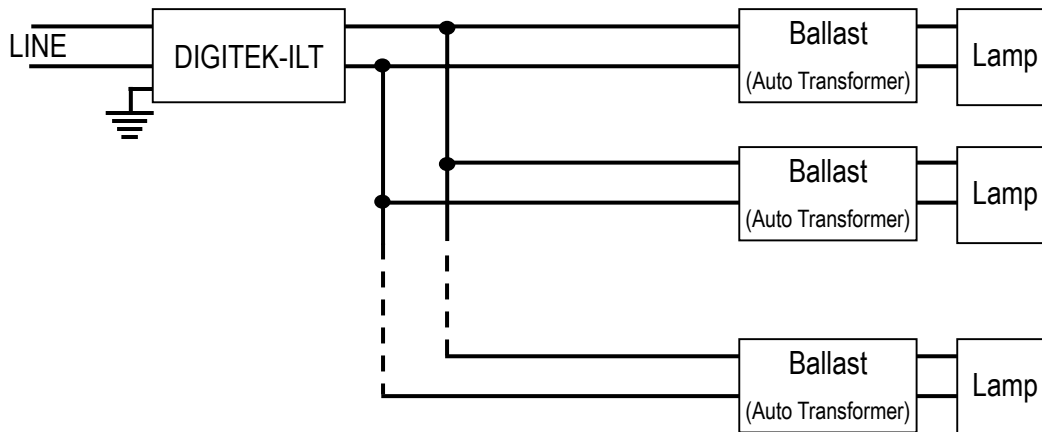

Fig. 6.5 Wire diagram for installing DIGITEK-ILT at the power supply of a lighting system without capacitor.

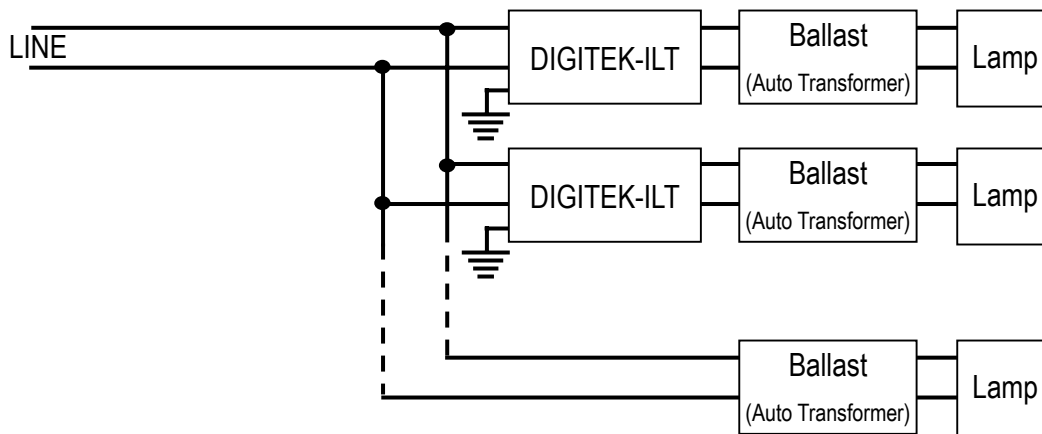

Fig. 6.6 Wire diagram for installing DIGITEK-ILT at the power supply of each lighting device of a lighting system without capacitor.

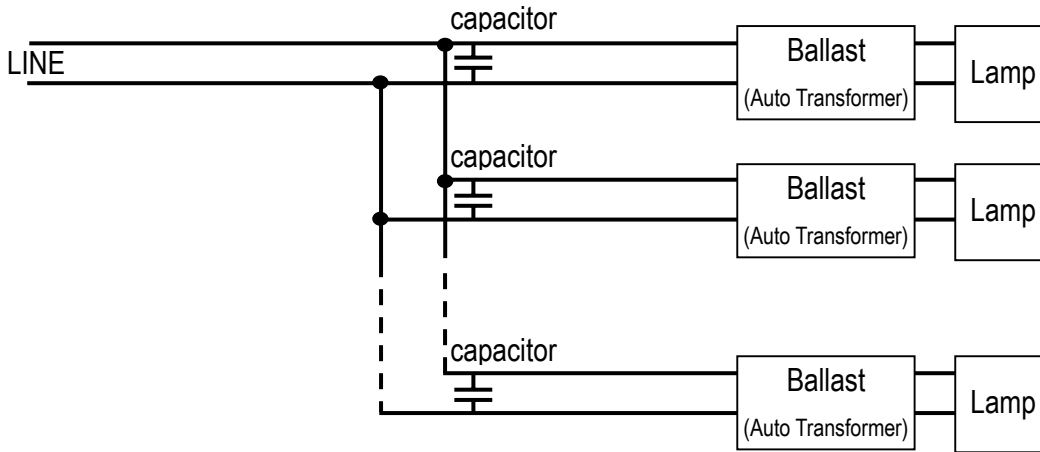

Fig. 6.7 Wire diagram for a lighting system with capacitors.

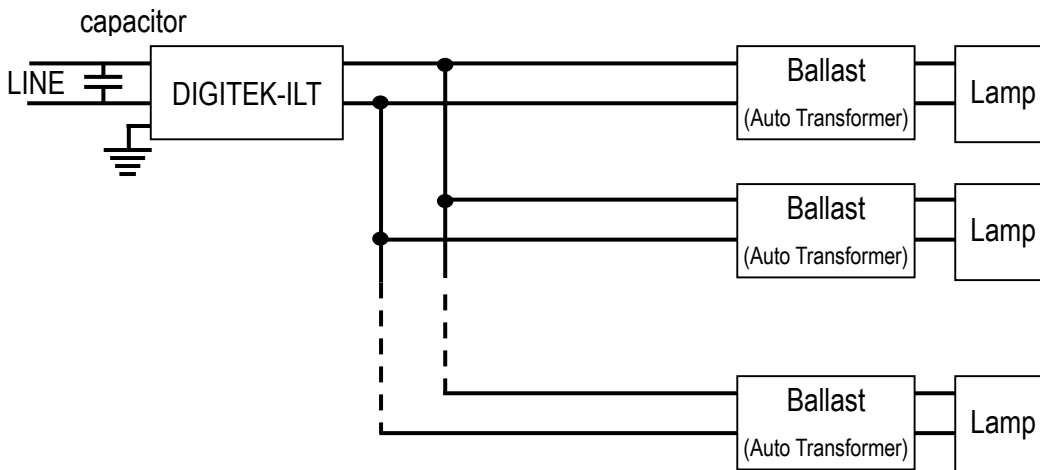

Fig. 6.8 Wire diagram for installing DIGITEK-ILT at the power supply of a lighting system with capacitors.

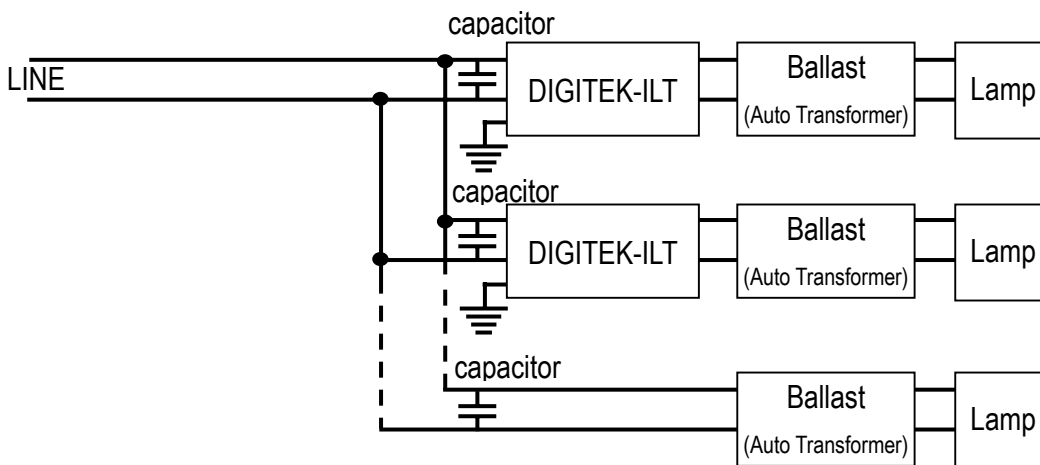

Fig. 6.9 Wire diagram for installing DIGITEK-ILT at the power supply of each lighting device of a lighting system with capacitors.

## 7. Energy Saving Tests

### 7.1. Fluorescent Light

Power supply rated voltage: 220V

Equipment: Fluorescent light tubes, 18W X 24

Dip switch setting: 1. ON 2. OFF

#### 7.1.1. Data

**Table 7.1.1a. KW without DIGITEK**

V (IN)	200	202	204	206	208	210	212	214	216	218	220	222	224	226	228	230	232	234	236	238	240
AMP	3.08	3.15	3.27	3.41	3.50	3.63	3.69	3.79	3.88	4.06	4.17	4.19	4.37	4.43	4.55	4.66	4.78	4.81	5.00	5.06	5.21
KW	0.45	0.46	0.47	0.49	0.50	0.51	0.52	0.54	0.55	0.56	0.57	0.57	0.58	0.59	0.60	0.61	0.62	0.63	0.65	0.67	0.68

**Table 7.1.1b. KW with DIGITEK**

V (IN)	200	202	204	206	208	210	212	214	216	218	220	222	224	226	228	230	232	234	236	238	240
V (OUT)	199	201	203	203	204	204	204	204	204	204	204	204	204	204	204	204	206	208	210	212	214
AMP	3.03	3.14	3.25	3.38	3.39	3.41	3.43	3.44	3.47	3.49	3.50	3.52	3.52	3.52	3.57	3.57	3.59	3.65	3.72	3.79	3.89
KW	0.43	0.44	0.45	0.46	0.46	0.46	0.46	0.47	0.47	0.47	0.47	0.47	0.47	0.47	0.47	0.47	0.48	0.49	0.49	0.51	0.53

**Table 7.1.1c. Energy Saving %**

V (IN)	200	202	204	206	208	210	212	214	216	218	220	222	224	226	228	230	232	234	236	238	240
w/t DIGITEK KW	0.45	0.46	0.47	0.49	0.50	0.51	0.52	0.54	0.55	0.56	0.57	0.57	0.58	0.59	0.60	0.61	0.62	0.63	0.65	0.67	0.68
w DIGITEK KW	0.43	0.44	0.45	0.46	0.46	0.46	0.46	0.47	0.47	0.47	0.47	0.47	0.47	0.47	0.47	0.47	0.48	0.49	0.49	0.51	0.53
ENERGY SAVING %	4.44	4.35	4.26	6.12	8.00	9.80	11.54	12.96	14.55	16.07	17.54	17.54	18.97	20.34	21.67	22.95	22.58	22.22	24.62	23.88	22.06

**Table 7.1.1d. Luminosity**

V (IN)	210	215	220	225	230	235	240
w/t DIGITEK LUX	271	286	298	314	323	333	342
w DIGITEK LUX	258	257	258	256	258	258	267

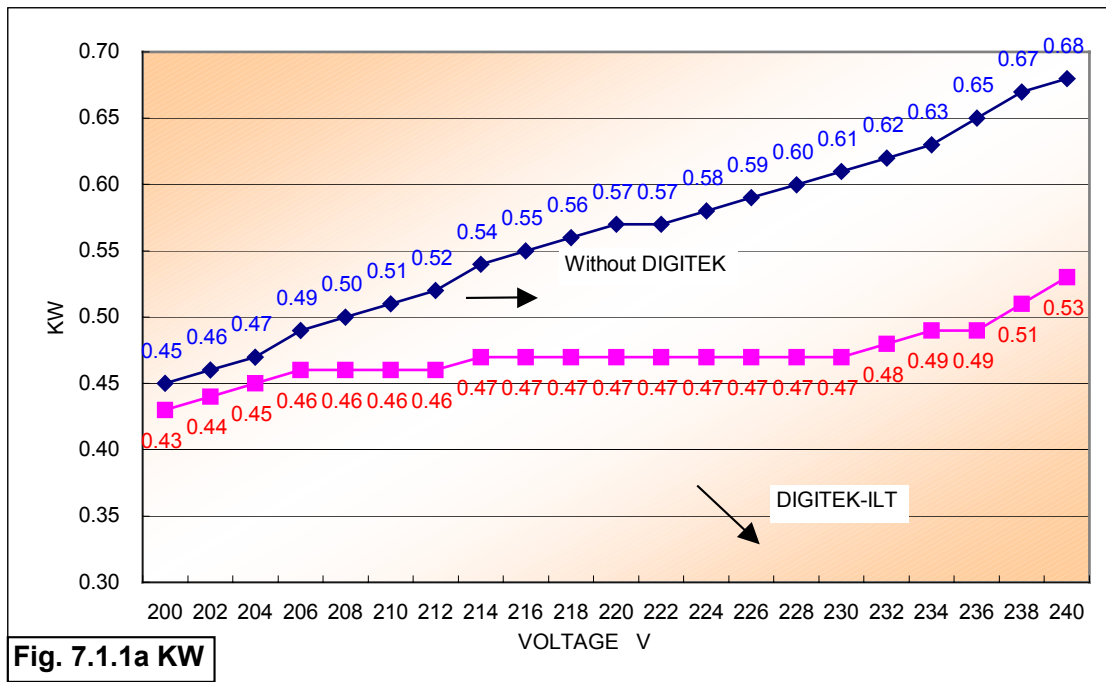
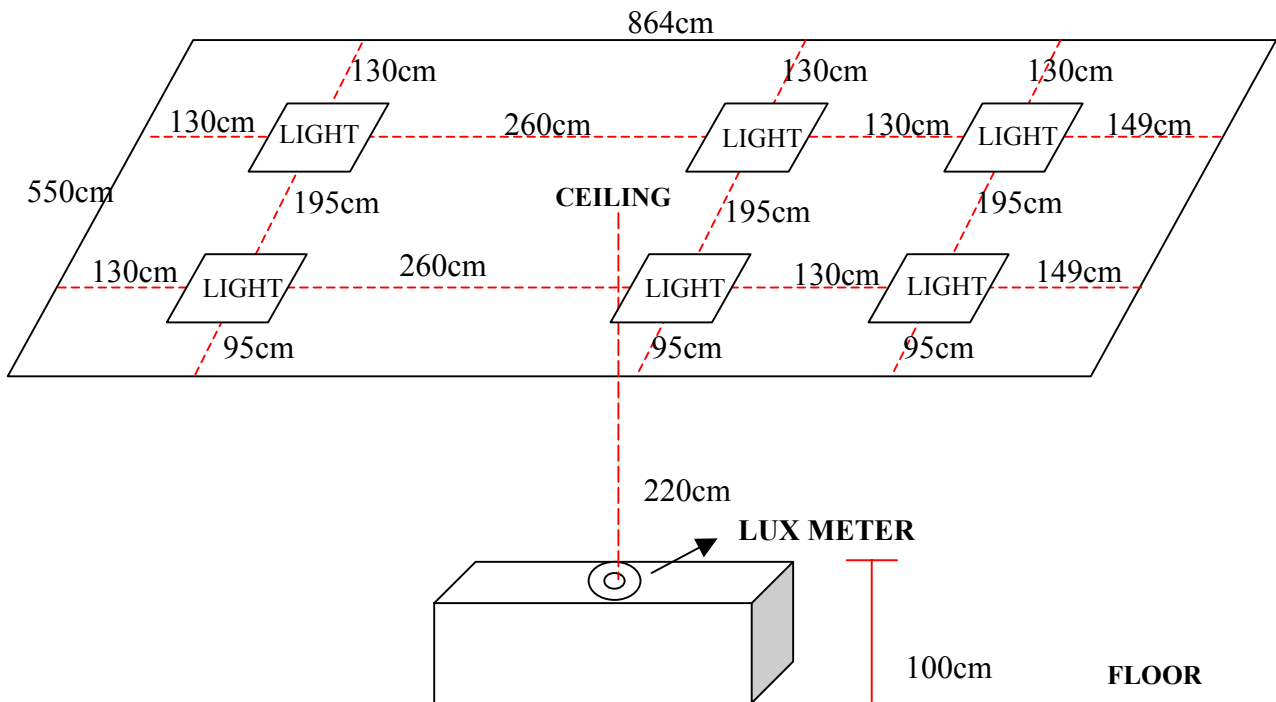

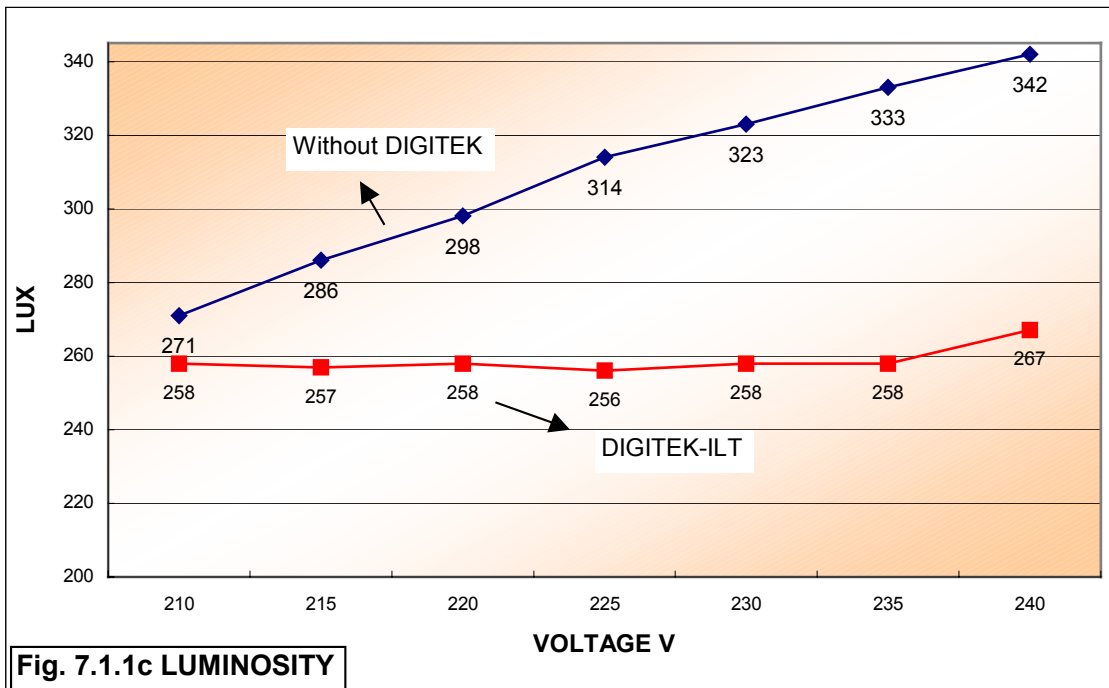
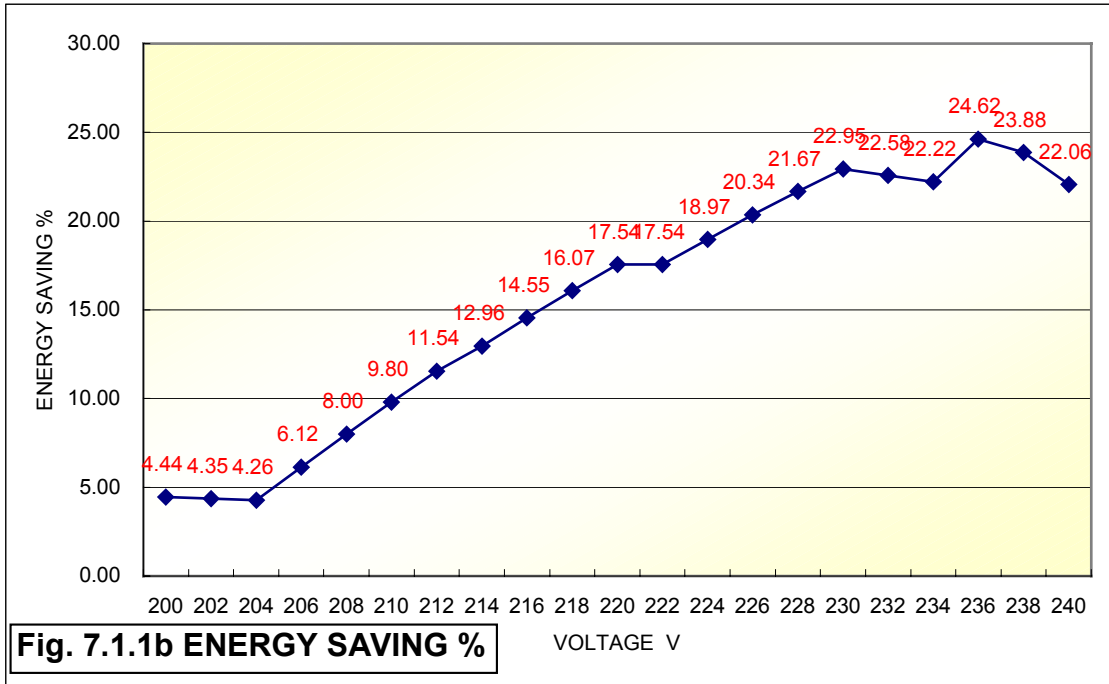

### 7.1.2. Saving on Electricity Bill:

- a. Based on the result shown above, installation of a 10 A unit on 50 tubes of 22W fluorescent light tubes can save:

Power supply voltage: 220 V

Energy saving per hour = 0.16 KW

Power supply voltage: 226 V

Energy saving per hour = 0.24KW

- b. For 24 hour operation convenient store:

Power supply voltage: 220 V

Energy saving per day = 0.16 KW X 24hours = 3.84KWH/day

Energy saving per year = 3.84KWH/day X 365days/year

= 1,401.6 KWH/year

For \$0.10/KWH

**Saving on electricity bill per year = \$0.10 X 1,401.6 = \$140.1**

Power supply voltage: 226 V

Energy saving per day = 0.24 KW X 24hours = 5.76KWH/day

Energy saving per year = 5.76KWH/day X 365days/year

= 2,102.4 KWH/year

For \$0.10/KWH

**Saving on electricity bill per year = \$0.10 X 2,102.4 = \$210.2**

### 7.1.3. Energy saving for different dip switch setting:

Dip Switch	1. ON 2. ON	1. OFF 2. ON	1. ON 2. OFF	1.OFF 2.OFF
Energy Saving%	21.05%	17.54%	14.04%	8.77%

## 7.2. Mercury Vapor HID

Power supply rated voltage: 230V

Equipment: Mercury HID, 200W X 2

Dip switch setting: 1. OFF 2. ON

### 7.2.1. Data

**Table 7.2.1a. KW without DIGITEK**

V (IN)	210	212	214	216	218	220	222	224	226	228	230	232	234	236	238	240	242	244	246	248	250
AMP	1.78	1.81	1.84	1.87	1.89	1.92	1.97	2.00	2.01	2.04	2.08	2.10	2.13	2.17	2.20	2.23	2.25	2.27	2.33	2.35	2.38
KW	0.37	0.38	0.39	0.39	0.40	0.41	0.42	0.43	0.44	0.45	0.46	0.46	0.47	0.47	0.48	0.49	0.50	0.51	0.52	0.53	0.54

**Table 7.2.1b. KW with DIGITEK**

V (IN)	210	212	214	216	218	220	222	224	226	228	230	232	234	236	238	240	242	244	246	248	250
V (OUT)	209	211	212	213	213	214	214	214	214	213	213	213	213	213	213	213	215	217	219	221	223
AMP	1.76	1.78	1.80	1.79	1.77	1.75	1.73	1.71	1.69	1.67	1.66	1.64	1.62	1.61	1.59	1.58	1.60	1.62	1.64	1.64	1.68
KW	0.35	0.36	0.36	0.36	0.36	0.36	0.36	0.36	0.35	0.35	0.36	0.36	0.36	0.35	0.35	0.35	0.35	0.36	0.36	0.37	0.38

**Table 7.2.1c. Energy Saving %**

V (IN)	210	212	214	216	218	220	222	224	226	228	230	232	234	236	238	240	242	244	246	248	250
w/t DIGITEK KW	0.37	0.38	0.39	0.39	0.40	0.41	0.42	0.43	0.44	0.45	0.46	0.46	0.47	0.47	0.48	0.49	0.50	0.51	0.52	0.53	0.54
w DIGITEK KW	0.35	0.36	0.36	0.36	0.36	0.36	0.36	0.36	0.35	0.35	0.36	0.36	0.36	0.35	0.35	0.35	0.35	0.36	0.36	0.37	0.38
ENERGY SAVING %	5.41	5.26	7.69	7.69	10.00	12.20	14.29	16.28	20.45	22.22	21.74	21.74	23.40	25.53	27.08	28.57	30.00	29.41	30.77	30.19	29.63

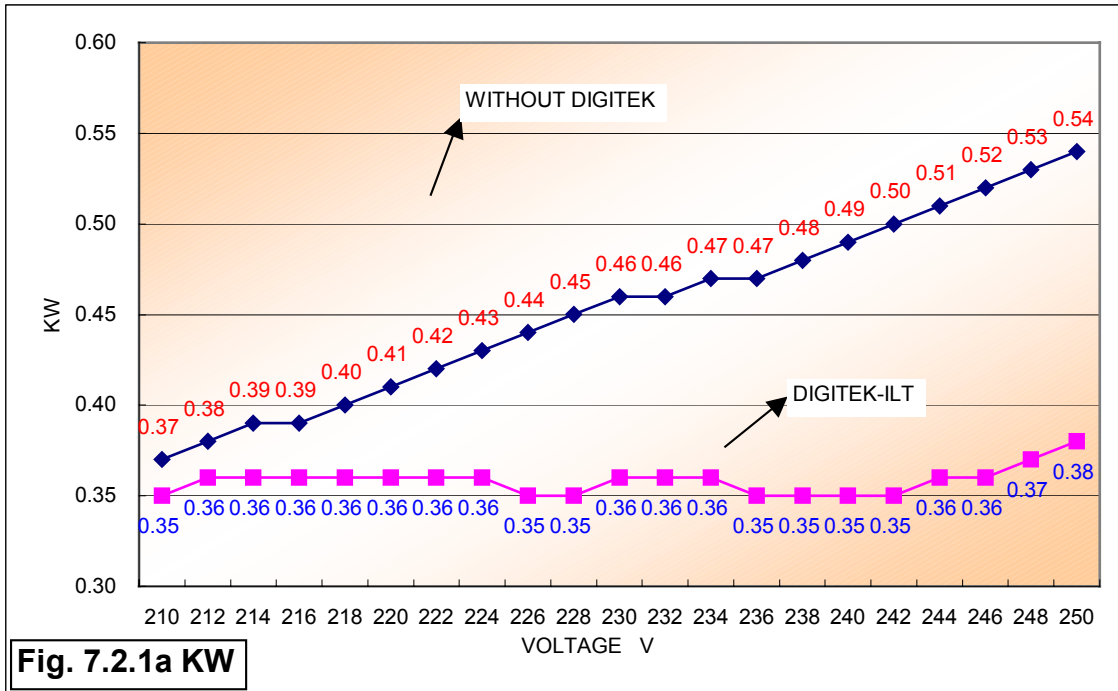

**Fig. 7.2.1a KW**

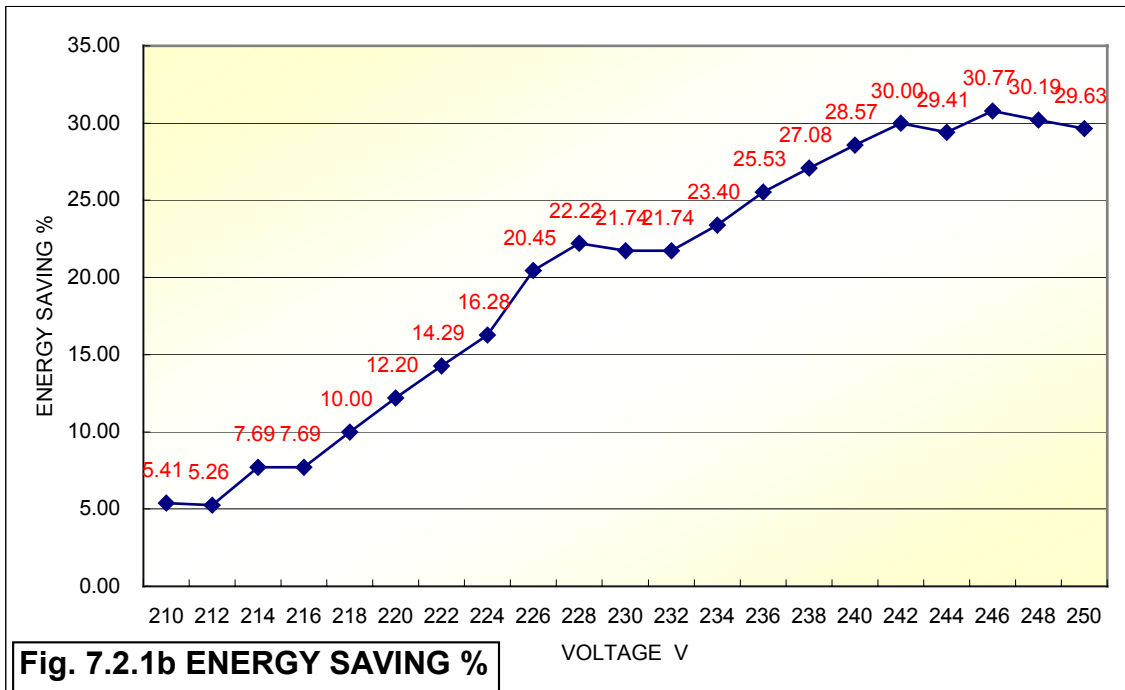

**Fig. 7.2.1b ENERGY SAVING %**

### 7.2.2 Voltage Drop and Energy Saving

Dip Switch	1. ON 2. ON	1. OFF 2. ON	1. ON 2. OFF	1.OFF 2.OFF
Energy Saving%	26.09%	21.74%	19.57%	15.22%

### 7.3. HID (Sodium)

Power supply rated voltage: 230V

Equipment: Sodium HID, 250W X 2

Dip switch setting: 1. OFF2. ON

#### 7.3.1. Data

**Table 7.3.1a. KW without DIGITEK**

V (IN)	210	212	214	216	218	220	222	224	226	228	230	232	234	236	238	240	242	244	246	248	250
AMP	2.47	2.50	2.52	2.53	2.56	2.60	2.63	2.65	2.66	2.70	2.72	2.75	2.77	2.79	2.82	2.85	2.87	2.89	2.92	2.95	2.97
KW	0.45	0.46	0.47	0.48	0.49	0.50	0.51	0.51	0.52	0.53	0.53	0.54	0.55	0.55	0.56	0.58	0.59	0.60	0.61	0.62	0.63

**Table 7.3.1b. KW with DIGITEK**

V (IN)	210	212	214	216	218	220	222	224	226	228	230	232	234	236	238	240	242	244	246	248	250
V (OUT)	209	211	212	212	211	212	212	212	211	210	209	210	209	210	209	209	210	212	214	217	219
AMP	2.43	2.44	2.44	2.40	2.30	2.21	2.10	2.09	2.03	1.98	1.93	1.88	1.83	1.81	1.75	1.72	1.73	1.73	1.75	1.79	1.81
KW	0.45	0.46	0.47	0.47	0.44	0.43	0.43	0.42	0.42	0.41	0.41	0.41	0.40	0.40	0.40	0.40	0.39	0.40	0.40	0.41	0.41

**Table 7.3.1c. Energy Saving %**

V (IN)	210	212	214	216	218	220	222	224	226	228	230	232	234	236	238	240	242	244	246	248	250
w/t DIGITEK KW	0.45	0.46	0.47	0.48	0.49	0.50	0.51	0.51	0.52	0.53	0.53	0.54	0.55	0.55	0.56	0.58	0.59	0.60	0.61	0.62	0.63
w DIGITEK KW	0.45	0.46	0.47	0.47	0.44	0.43	0.43	0.42	0.42	0.41	0.41	0.41	0.40	0.40	0.40	0.40	0.39	0.40	0.40	0.41	0.41
ENERGY SAVING %	0.00	0.00	0.00	2.08	10.20	14.00	15.69	17.65	19.23	22.64	22.64	24.07	27.27	27.27	28.57	31.03	33.90	33.33	34.43	33.87	34.92

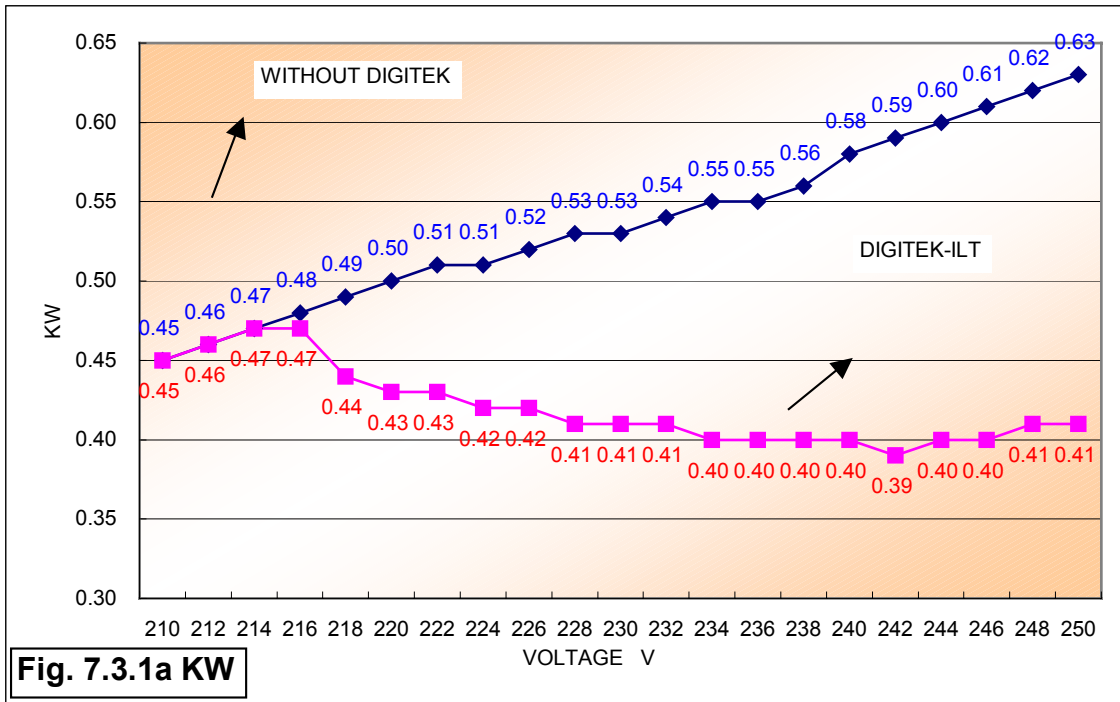

**Fig. 7.3.1a KW**

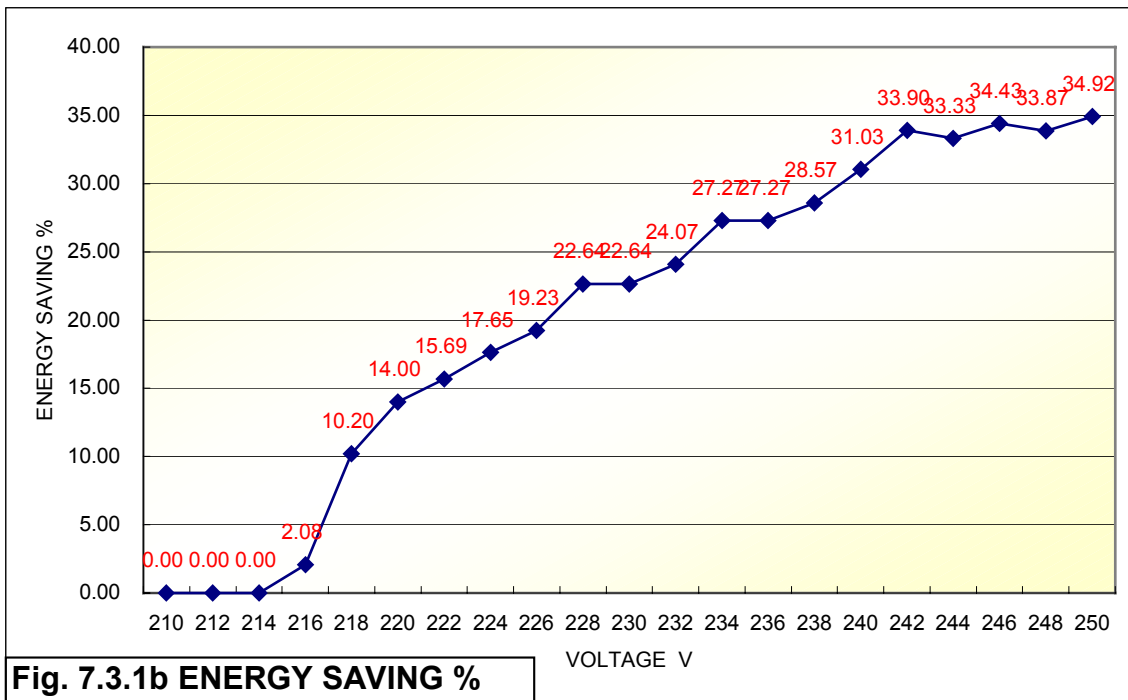

**Fig. 7.3.1b ENERGY SAVING %**

**7.3.2. Voltage Drop and Energy Saving**

Dip Switch	1. ON 2. ON	1. OFF 2. ON	1. ON 2. OFF	1.OFF 2.OFF
Energy Saving%	30.19%	22.64%	16.98%	11.32%

**DIGITEK**

DIGITEK TECHNOLOGY  
02/24/2004